

MAXITROL

Selectra® Modulating Valves for Atmospheric, Infrared, and Direct Fired Burners

M/MR Series

TABLE OF CONTENTS

Introduction	2
Direct Fired Applications (Negative Pressure)	2
Direct Fired Applications (Positive Pressure)	3
Indirect Fired Applications	3
'H' Suffix M/MR Valves	3
Specifications	4
Application Table	5
Dimensions	6
Capacities	7
Typical Gas Trains	8
Installation of MR410, MR510, & MR610 Valve	8



M411, M511, M611
M420, M520, M620
MR410, MR510, MR610
MR212D, MR212E, MR212G
and MR212J (Flanged)
MR251D, MR251E, MR251G
M451, M551, M651

"H" suffix models for use with LP and other applications: M420H, M520H, M620H, MR410H-1, MR510H-1, MR610H-1

- Absolutely **NO EXTERNAL MECHANICAL ACTIVATION** required.
- MR Valve (only) performs dual function of modulation and pressure regulation.
- Provides infinite, continuous flame adjustment.
- May be factory installed or added in the field.
- Capacities to 30,000 CFH.
- Available in a wide range of body styles and pipe sizes.
- Designed for use with the Maxitrol Selectra® series of modulation systems - or SC10 Signal Conditioners convert computer/PLC controller signals if standard Maxitrol companion controls are not specified.

Maintaining consistent temperatures is no longer a problem. The unique Modulator or Modulator/Regulator valve, the heart of the Selectra® Electronic Gas Flame Modulating System, provides precise, non-fluctuating, instantaneous temperature control - without requiring any motor or mechanically driven butterfly valve.

Whether your needs are problem-free stabilized area heating, elevated heating, consistent higher baking/drying temperatures or other process applications.



Figure 1 : MR212

INTRODUCTION

To evaluate which valve will satisfy your needs, it is necessary to determine the application. The first, and most basic breakdown, is direct versus indirect fired appliances.

Direct fired units do not have a heat exchanger and all products of combustion generated by the gas burning device are released directly into the airstream being heated. They are commonly used in space heating or make up air applications, process drying, and baking ovens.

Direct fired burners have raw gas injected into the burner and the burner relies entirely on the air being pulled across the burner for combustion air. It may take advantage of the mixing effects of the blower by using a **pull through** system which locates the burner on the suction side of the blower. This means the air being pulled across the burner is at a negative pressure (usually not greater than -1.5" w.c.). Other direct fired applications may use a **push through** systems which locates the burner downstream from the blower. This means the air being pushed across the burner is at a positive pressure (usually not greater than 3" w.c.)

Direct fired burners can be of extremely high turn down ratios, in some instances, 30:1. The high turn down ratio allows the minimum temperature rise to be low enough that the unit does not have to be cycled on and off to maintain temperature.

Indirect fired appliances utilize a heat exchanger and all products of combustion generated by the gas burning device are vented outdoors. They are usually supplied with an atmospheric burner or a power burner.

The other burner is the atmospheric burner. The air being supplied to this burner is at atmospheric pressure. They have limited turndown ratios (maximum input: minimum input) of usually 3:1 or 4:1. Due to limited turndown ratio, the minimum temperature rise cannot be held low enough and as a result, the main gas valve must usually be cycled to maintain temperature.

A power burner is a burner in which either the gas, air, or both are supplied at pressures exceeding line pressure for gas and atmospheric pressure for air. Maintaining the proper gas-air mixture for modulation usually requires pressure control of both the air and gas. Burners of this type are not capable of modulation with the Maxitrol Selectra® system.

DIRECT FIRED

Valves designed for direct fired applications (negative pressure/pull through) M411, M511, M611, MR212D, MR212E, MR212G, and MR212J

These valves are designed exclusively for negative pressure (pull through) applications. They use a counter spring to keep the valve in the close position despite the downward pull of negative pressure. M411, M511, and M611 valves are set for applications up to 1.5" w.c. and are not adjustable. MR212 valves are factory set for applications up to -1.5" w.c. and are field adjustable for up to -3.5" w.c.

With the main valve closed an adjustable bypass provides a minimum firing rate to the burner whenever the safety shut-off valve(s) is open. This is low fire to the heater. Since the pressure regulator maintains a constant supply pressure, the minimum firing rate is also held constant. The MR212's regulator is an integral component while a separate upstream pressure regulator is required for the M411, M511, and M611.

As voltage is applied to the control's solenoid, a magnetic force is applied to the plunger. The plunger in turn pushes down on the main diaphragm of the M411, M511, and M611 valves or allows pressure to develop in the upper chamber of the MR212 valve. These forces on the main diaphragm are very similar to the spring loading of a gas pressure regulator. When the force is sufficient to overcome the counter spring the main valve will open and gas will flow through the main valve in addition to flowing through the bypass. With sufficient voltage, the main valve (modulator valve for the MR212) will fully open and the pressure regulator will limit the burner pressure to the desired amount, thus establishing a controlled maximum high fire condition.

We now have two extremes. The first is low fire with no force on the plunger and flow through the bypass only. The second is high fire with sufficient force on the plunger to fully open the valve (modulator valve for the MR212), with the gas pressure regulator controlling the maximum firing pressure. Force on the plunger between these extremes results in modulated gas flow. The voltage versus outlet pressure curve, throughout the modulating range, is fairly linear.

There are also applications where it is desirable to have two separate high fire burner settings. Typical applications would be a two speed fan operation or LP natural gas change over. This is accomplished by adding an adjustable resistance to the circuit, thereby limiting voltage to the valve. Changing from one setting to another is done by connecting a single pole single throw switch (customer supplied) that when in the open position allows the outlet pressure to be adjusted up to 2" w.c. below normal maximum high fire. Negative pressure valves designed for dual pressure settings are designated with a - 2 suffix

(example: MR212D-2). Field conversion kits (KT/10542) to modify single pressure valves are also available.

The working voltage to operate the modulating controls can be supplied by the A1014, A1024, A1044, A1494 and AD1094 Amplifiers or the SC10 Signal Conditioner. (Refer to Bulletin SEL1444_CC_EN, SEL94_CC_EN, and SC10C_MS_EN).

Valves designed for direct fired applications (positive pressure/push through) MR212D-1, MR212E-1, MR212G-1, and MR212J-1.

The valve's operating principles are identical to the negative pressure MR212. The only difference is the valve has been designed to operate on positive pressure (push through) applications. Positive pressure valves designed for dual pressure settings are designated with a - 3 suffix (example: MR212D-3).

INDIRECT FIRED

Valves designed to operate on indirect fired atmospheric burner applications M420, M520, M620.

These valves function in the same manner as the direct fired M valves. A pressure adjustment spring has been factory set to obtain an outlet pressure slightly above atmospheric pressure (0.1" w.c.) with the bypass closed and zero voltage being applied. The minimum flow rate is now adjusted through the bypass.

NOTE: Minimum outlet pressure is always above 0.2" w.c. - maximum outlet pressure is 7.0" w.c.

They can be driven by the A1094 and AD1094 Amplifiers or SC10 Signal Conditioners. (SEL94_CC_EN & SC10C_MS_EN)

Valves designed to operate on indirect fired atmospheric burner applications M451, M551, M651, MR251D, MR251E, MR251G.

These valves function in the same manner as the direct fired M valves. Minimum input pressure is set using a minimum adjustment spring - the valves do not use a bypass.

They are used in applications where the minimum input pressure to burner is between 2.0" and 4.5" w.c. Maximum obtainable outlet pressure is 7.0" w.c. above minimum input pressure.

The valves are driven by the A1094 and AD1094 Amplifiers or SC10 Signal Conditioners. (Refer to Bulletin SEL94_CC_EN & SC10C_MS_EN)

MR410, MR510, and MR610

These valves use two springs in order to set the high and low fire settings. One spring (min.) surrounds the solenoid and is always in contact with the diaphragm assembly. The other spring (max.) is located above the plunger. With zero voltage applied, the minimum and maximum spring's down force, along with plunger weight, pushes down on the diaphragm thereby setting a regulated high fire. A separate pressure regulator is not required. As voltage is applied, the plunger pulls up sufficiently until all plunger weight and maximum spring force is removed. The pressure is now controlled with the minimum spring setting giving a regulated low fire condition. Force on the plunger between the extremes results in modulated gas flow. The voltage versus outlet pressure curve, throughout the modulating range, is not linear.

These valves are driven with the A1010 or A1011 Amplifier or SC10 Signal Conditioners. (Refer to Bulletin SEL2030_2131_CC_EN & SC10C_MS_EN)

'H' SUFFIX MODELS

Valves designed with wider modulation span for use with LPG (liquid propane gas) and other applications MR410H-1, MR510H-1, MR610H-1, M420H, M520H, M620H.

Can be configured for indirect fired atmospheric burner applications, as well as those with direct fired burners.

H-1 models are designed for applications with a total modulation span greater than 7" w.c. Minimum outlet pressure range of 1" to 2.8" w.c.

H models are designed for applications where outlet pressure is greater than 7" w.c. Minimum outlet pressure is factory set to 1.75" w.c. - remaining set pressure is obtained through bypass.

The H models are capable of a total modulation span of as much as 10" w.c. These models are not recommended for applications with a total modulation span of less than 7" w.c. - the sensitivity of outlet pressure change relative to voltage change could cause hunting to occur.

NOTE: Temperatures shown in text are for Maxitrol's Selectra® systems. *Valves may be used for any temperature range or application the user's controller can handle.* When using valves for other ranges, a Maxitrol SC10 Signal Conditioner can be used in conjunction with the valve. (Refer to Bulletin SC10C_MS_EN)

SPECIFICATIONS

Vent:

Models M411, M511, M611, M420, M520, M620, M420H, M520H, M620H, MR410H-1, MR510H-1, MR610H-1, M551, M651 - vertical vent outlet 1/8" NPT - 12A06 installed.

Models MR212 and MR251 - two vents located in upper housing, both equipped with vent limiting means.

Ambient Limits:

Operating -40° to 125°F (-40° to 50°C)

Non-operating -50° to 185°F (-45° to 85°C)

Mounting:

Must be mounted in upright position in horizontal pipe run, downstream of all other controls except high pressure cut-off switch if used. (See page 8)

Gases:

Natural, Manufactured, Mixed, Liquefied Petroleum and Liquefied Petroleum Gas Air Mixture H, H-1 models for use with Liquefied Petroleum and other applications.

Certifications:

M611, MR212D, E, & G with Series 14: CSA listed to certify compliance with nationally published safety, construction, and performance standards.

M411, M420, M420H, M451, M511, M520, M520H, M611, M620, M620H, MR212D, E, G, & J with AD1094 controls: CSA listed to certify compliance with nationally published safety, construction, and performance standards.

MR410, MR410H-1, MR510, MR510H-1, MR610, and MR610H-1: CSA certified to Z21.18 and CSA 6.3-M82.

M611, MR212D, E, & G: UL recognized for compliance to nationally published safety, construction, and performance standards.



Model	Coil Resistance Ohms @ 68°F	Maximum Current Draw
MR410, MR410-1, M411, M420, M451, MR212, MR251	64	400 mA
MR510, MR510-1, M511, M520, M551	55	500 mA
MR610, MR610-1, M611, M620, M651	46	600 mA
MR410H, MR410H-1, M411H, M420H, MR212H	40	700 mA
MR510H, MR510H-1, M511H, M520H	33	850 mA
M610H, MR610H-1, M611H, M620H	29	1000 mA

M/MR SERIES APPLICATIONS TABLE

Model Number	Max. Current Draw (amps)	Application	Function	CSA Tested* Inlet Pressure	Inlet Pressure Operating Limits	Upstream Pressure Regulator Required	Maximum Emergency Exposure	Output Control Means Standard Factory Setting (if applicable)	System Used With
M411 M511 M611	0.4 0.5 0.6	Direct Fired (Negative Pressure) Burners	Increase in voltage corresponds to increase in outlet pressure	1/2 psi (34 mbar)	Upstream pressure regulator setting	Yes	2.5 psi (170 mbar)	Low Fire: adjustable orifice bypass High Fire: upstream pressure regulator setting less pressure drop Note: 7" w.c. (17 mbar) max outlet pressure	Series 14, 24, 44, 94, SC10
M420 M420H M520 M520H M620 M620H	0.4 0.7 0.5 0.85 0.6 1.0	Atmospheric Burners H Models for higher outlet pressures (such as LP applications)	Increase in voltage corresponds to increase in outlet pressure	1/2 psi (34 mbar)	Upstream pressure regulator setting	Yes	2.5 psi (170 mbar)	Low Fire: adjustable orifice bypass High Fire: upstream pressure regulator setting less pressure drop Note: 7" w.c. (17 mbar) max outlet pressure Note: H models: 11" w.c. (27 mbar) max outlet pressure	Series 94, SC10
M451 M551 M651	0.4 0.5 0.6	Atmospheric Burners - where higher outlet pressures are needed	Increase in voltage corresponds to increase in outlet pressure	1/2 psi (34 mbar)	Upstream pressure regulator setting	Yes	2.5 psi (170 mbar)	Low Fire: spring adjustment Std. Model: 1.2" - 2.5" w.c. (3-6.2 mbar) -1 models: 2" - 4.5" w.c (5-11 mbar) High Fire: upstream pressure regulator setting less pressure drop	Series 94, SC10
MR251D MR251E MR251G	0.4	Atmospheric Burners - where higher outlet pressures are needed	Increase in voltage corresponds to increase in outlet pressure	--	5 psi (340 mbar)	No	12.5 psi (860 mbar)	Low Fire: spring adjustment 2" - 4.5" w.c. (5-11 mbar) High Fire: maximum 7" w.c. (17 mbar) above minimum setting	Series 94, SC10
MR212D MR212E MR212G MR212J	0.4	Direct Fired (Negative Pressure) Burners	Increase in voltage corresponds to increase in outlet pressure	CSA Rated [^] Inlet Pressure 5 psi (340 mbar)	5 psi (340 mbar)	No	12.5 psi (860 mbar)	Low fire: adjustable orifice bypass High fire: spring adjustment High Fire Setting: Std. model: 2.5" w.c. (5-12.5 mbar) reduced to 0-3" w.c. (0-7.5 mbar) -2 model: 2" - 5" w.c. (5-12.5 mbar) reduced to 0-3" w.c. (0-7.5 mbar)	Series 14, 24, 44, 94, SC10
MR410 MR410H-1 MR510 MR510H-1 MR610 MR610H-1	0.4 0.7 0.5 0.85 0.6 1.0	Atmospheric Burners H-1 models for higher outlet pressure (such as LP applications)	Decrease in voltage corresponds to increase in outlet pressure	1/2 psi (34 mbar)	1 psi (70 mbar)	No	2.5 psi (170 mbar)	Low fire: spring adjustment High fire: spring adjustment Std. model: 2" - 5" w.c. (5-12.5 mbar) max-4" w.c. (10 mbar) -1 model: min-1.5" w.c. (3.75 mbar) max-4" w.c. (10 mbar) H-1 model min outlet pressure = 1.75" w.c. (4.4 mbar) max outlet pressure = 11" w.c. (27 mbar) Note: H-1 models: 7.5" to 12" w.c. max outlet pressure	Series 20, 21, 30, 31

* Where no ANSI standard currently exists, Maxitrol Controls have been CSA tested for use as a component of Maxitrol Selectra[®] systems. [^]CSA Rated Inlet Pressures are established by ANSI standard Z21.18, CSA 6.3, and CSA 6.5 where applicable.

DIMENSIONS

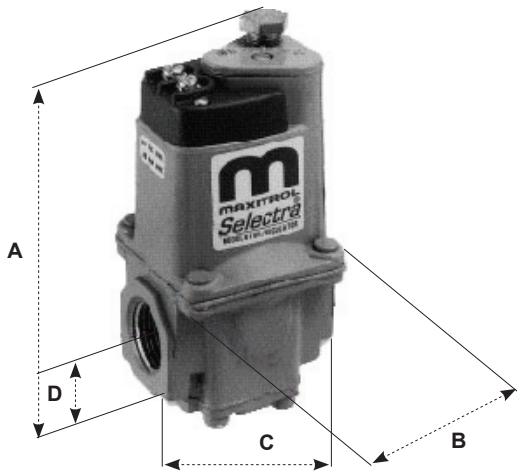

Figure 2 : MR410, 510, 610, MR410H-1, 510H-1, 610H-1, M451, 551, 651

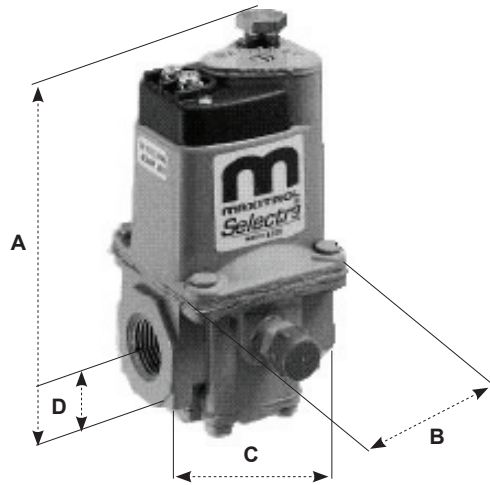

Figure 3 : M411, 511, M420H, 520H, 620H, M420, 520, 620

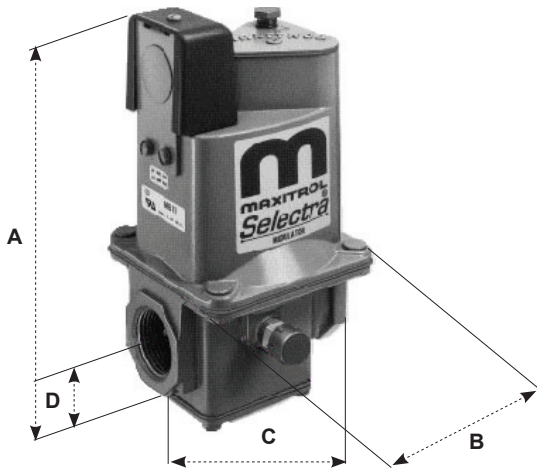

Figure 4 : M611

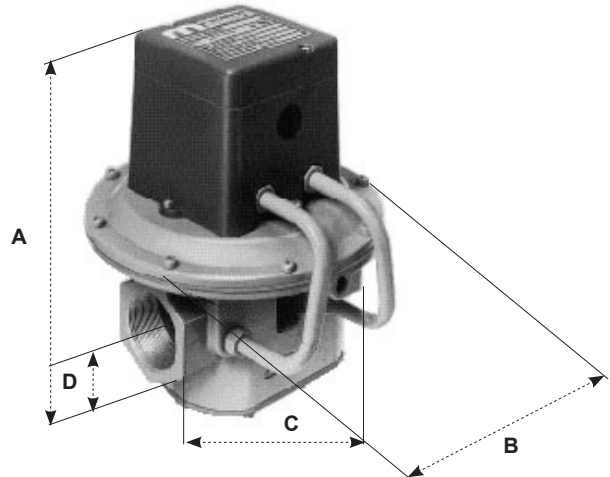

Figure 5 : MR212, MR251*
(*Same as MR212 except single by-pass)

Dimensions - in inches (millimeters)

Dimension are to be used only as an aid in designing clearance for the valves.
Actual production dimensions may vary somewhat from those shown.

Model Number	Swing Radius	Dimensions			
		A	B	C	D
MR410, MR410H-1, M411, M420, M420H, M451	3.1 (79)	3.9 (100)	2 (51)	2.5 (54)	0.9 (24)
MR510, MR510H-1, M511, M520, M520H, M551	4.3 (109)	5.3 (135)	3.25 (83)	3.4 (86)	1.2 (30)
MR610, MR610H-1, M620, M620H, M651	5.7 (145)	7.1 (180)	3.9 (99)	4 (102)	1.5 (37)
M611	6.2 (158)	7.7 (196)	3.9 (99)	4 (102)	1.5 (37)
MR212D, MR251D	8.1 (206)	10.2 (259)	7 (178)	5.5 (140)	2.3 (59)
MR212E, MR251E	8.6 (218)	11.25 (286)	9.1 (232)	8 (203)	3 (76)
MR212G, MR251G	10.4 (264)	14.75 (375)	13.5 (343)	11.75 (298)	4.6 (118)
MR212J (Not Shown)	--	24 (610)	21.5 (546)	13.9 (352)	5.9 (149)

CAPACITIES

Capacity - flow rate expressed in CFH (m³/h) - 0.64 sp gr gas, Pressure drop expressed in inches w.c. (millibars)

Consult with Maxitrol Company, for flows in excess of those shown below.

Model Number and Pipe Size		100 (2.83)	150 (4.25)	200 (5.66)	250 (7.1)	300 (8.5)	350 (9.9)	400 (11.3)	450 (12.7)	500 (14.2)	600 (17.0)	700 (19.8)	750 (21.2)	Min. Flow
MR410 MR410H-1 M411	3/8X3/8	0.33 (0.82)	0.75 (1.88)											†5-90 (0.14-2.5)
	M420† M420H M451	1/2X1/2	0.27 (0.67)	0.61 (1.53)										
MR510 MR510H-1 M511†	1/2X1/2		0.17 (.42)	0.30 (.75)	0.47 (1.18)	0.67 (1.68)	0.92 (2.30)							†5-125 (0.14-3.5) ‡5-185 (0.14-5.2)
	M520‡ M520H M551	3/4X3/4	0.12 (0.30)	0.21 (0.52)	0.32 (0.80)	0.47 (1.18)	0.64 (1.60)	0.83 (2.07)						
MR610 MR610H-1	3/4X3/4				0.14 (.35)	0.20 (.50)	0.27 (.67)	0.36 (.90)	0.45 (1.13)	0.56 (1.40)	0.81 (2.03)			†10-330 (0.28-9.3)
	M620† M620H M651	1X1			0.12 (0.30)	0.16 (0.40)	0.22 (0.55)	0.29 (0.72)	0.37 (0.92)	0.45 (1.13)	0.66 (1.65)	0.90 (2.25)	1.00 (2.50)	

† or ‡ Models to which min. flow applies. (Minimum flow maximum calculated ΔP = 3.5" w.c. [single by-pass])

Model Number and Pipe Size		100 (2.83)	150 (4.25)	200 (5.66)	300 (8.5)	400 (11.3)	500 (14.2)	600 (17.0)	700 (19.8)	800 (22.7)	900 (25.5)	1000 (28.3)	CSA Listed	Min. Flow
M611*	3/4x3/4	0.02 (0.05)	0.06 (0.15)	0.09 (0.23)	0.20 (0.50)	0.36 (0.90)	0.56 (1.40)	0.81 (2.03)	1.10 (2.75)	1.45 (3.63)	1.83 (4.58)		1000	10-330 (0.28-9.3)
	1x1	0.02 (0.05)	0.05 (0.12)	0.07 (0.18)	0.16 (0.40)	0.29 (0.72)	0.46 (1.15)	0.66 (1.65)	0.90 (2.25)	1.18 (2.95)	1.50 (3.75)	1.85 (4.63)		

Model Number and Pipe Size		1000 (28.3)	1500 (42.5)	2000 (56.5)	2500 (70.8)	3000 (85.0)	3500 (99.0)	5000 (142)	6000 (170)	7000 (198)	10000 (283)	11000 (311)	CSA Listed	Min. Flow Min. Flow Applies to MR212s only
MR212D* MR251D	1x1	1.9 (4.75)	2.9 (7.25)	4.9 (12.25)	6.2** (15.50)								2250	25-300 (0.71-8.5)
	1¼x1¼	1.7 (4.25)	2.3 (5.75)	3.1 (7.75)	4.8 (12.00)	5.9** (14.75)							2750	
	1½x1½	1.7 (4.25)	2.2 (5.50)	2.9 (7.25)	3.9 (9.75)	5.4 (13.50)							3000	
MR212E*	1½x1½			1.9 (4.75)	2.4 (6.00)	2.9 (7.25)	3.5 (8.75)	6.0** (15.00)					4750	25-300 (0.71-8.5)
MR251E	2x2			1.9 (4.75)	2.1 (5.25)	2.4 (6.00)	2.7 (6.75)	5.5 (13.75)	6.0** (15.00)				5250	
MR212G*	2½x2½						1.9 (4.75)	2.2 (5.50)	2.6 (6.50)	3.0 (7.50)	6.1 (15.25)		10000	50-450 (1.4-12.7)
MR251G	3x3							2.1 (5.25)	2.3 (5.75)	2.6 (6.50)	4.6 (11.50)	5.6 (14.00)	11000	

*U.L. recognized

**Pressure Drop figures derived from CSA Maximum Listed Capacities in far right column (not flow at column top).

Model Number and Pipe Size		6000 (170)	8000 (227)	10000 (283)	12000 (340)	14000 (397)	16000 (397)	18000 (510)	20000 (566)	22000 (623)	24000 (680)	27000 (765)	30000 (850)	Min. Flow
MR212J	4x4	1.9 (4.75)	2.1 (5.25)	2.4 (6.00)	2.7 (6.75)	3.1 (7.75)	3.6 (9.00)	4.5 (11.25)	5.4 (13.50)	6.6 (16.50)	7.8 (19.50)	9.9 (24.75)	12.4 (31.00)	1-1000 (0.03-28.3)

TYPICAL GAS TRAINS

Modulator (M) or Modulator-Regulator (MR) Valve: Mount in upright position in horizontal run of pipe, downstream of other controls - a separate gas pressure regulator must be used with any modulator (M) valve.

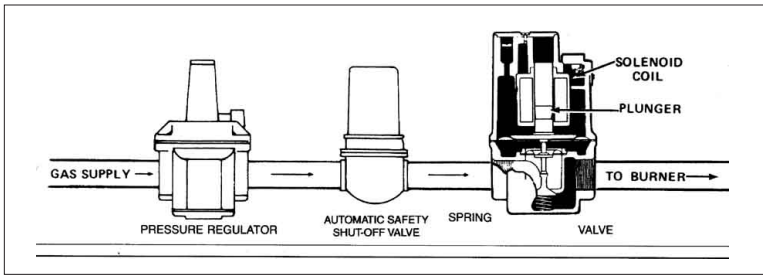

Figure 6 : M Valve: Regulator upstream of modulator valve

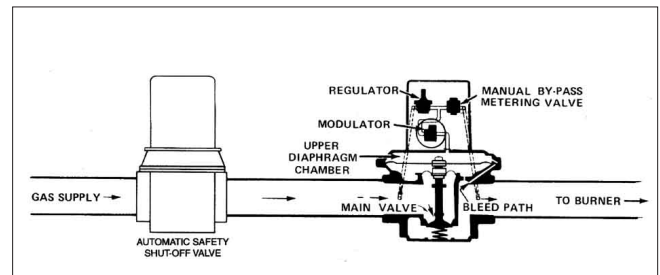

Figure 7 : MR Valve: Modulator-Regulator valve

INSTALLATION OF MR410, MR510, MR610 VALVE

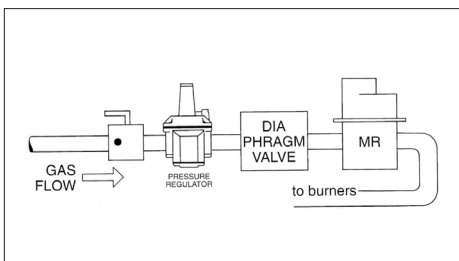

Figure 8 : If diaphragm type automatic gas valve is used with separate regulator, install MR valve downstream from diaphragm gas valve. Retain regulator in manifold and adjust 2 or 3 turns to compensate for pressure drop of MR valve.

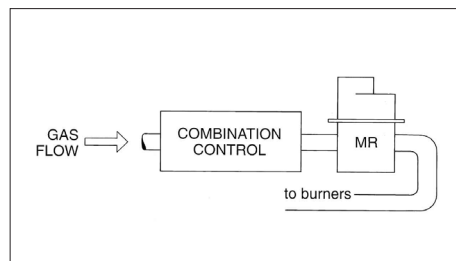

Figure 9 : If full combination control is used, install MR valve downstream. Adjust regulator in combination control 2 or 3 turns to compensate for pressure drop at MR valve.

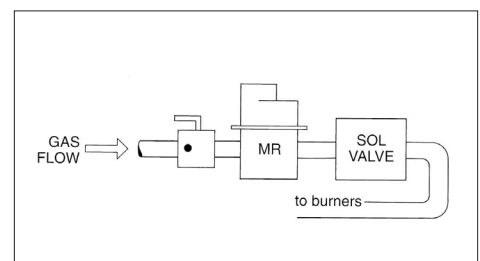

Figure 10 : If solenoid type automatic gas valve is used with separate regulator, replace regulator with the MR valve.

MR Valve **must** be in upright position, in horizontal run of pipe only **with pilot gas supply upstream**.

MODIFICATIONS

Models having the letters B, H, M, R, or W, or a combination of these suffix letters, indicates the design modification described below:

B - both sides fitted for low fire adjustment.

H - capable of a total modulation span of as much as 10" w.c.

M - PL parallel thread conforms to ISO 7-1.

R - Right side outlet - low fire by-pass adjustment on right side.
Available on models: M411, M511, M420, and M520.

W - Indicates covered wire terminal connections, same as M611.
Available on models: M411, M511, M420, M520, M620, M451, M551, and M651.

Note: Models M411, M511, and M611 are available with 1/8" NPT connection for reading outlet pressure. Not available on "B" models connection is located on opposite side of by-pass adjustment. (See *Dimensions* section of this bulletin)

MAXITROL